

Watertight With Bottom Flange (1590W Series)

Bottom flange is an aluminum plate, welded onto the base of the enclosure...

Lid screws are exposed for easy enclosure access...

Countersunk lid with stainless steel machine screws into drilled and tapped holes with individual neoprene "O" rings...



Vibra finished for a smooth surface with no sharp edges...

Lap joint construction with a bead of silicone rubber around the lid perimeter...

OTHER KEY FEATURES

- Rugged, diecast aluminum alloy (tough yet easy to machine), electronic instrument enclosure.
- Two piece lap joint construction with a bead of silicone rubber around the perimeter provides protection against access of dust and water. Silicone rubber remains usable from -62 to +232°C (-80 to +450 °F)
- Painted version is painted with tough polyester powder paint for a lasting finish, even after machining.
- Four (or 6 in 1590D, 1590DD & 1590E, 8 in 1590F) 6-32 x 1/2" stainless steel machine screws secure lid - into tapped holes.
- Low side wall draft angle (2 degrees or less) for easy P.C. board mounting.
- Designed to meet IP65
- Replacement screws for natural finish series, stainless steel, 6-32 x 1/2" - **1590WMS100**
- Replacement black oxide screws for black finish, stainless steel, 6-32 x 1/2" - **1590WMS100BK**

Enclosure uses black stainless steel machine screws into drilled & tapped holes with individual rubber "O" rings...

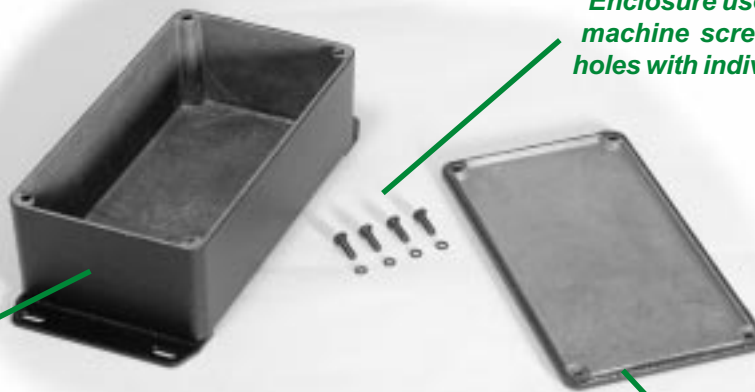

Vibra finished for a smooth surface with no sharp edges, then painted with tough polyester powder paint...

Lap joint construction with a bead of silicone rubber around the lid perimeter...

Watertight With Bottom Flange (1590W Series)

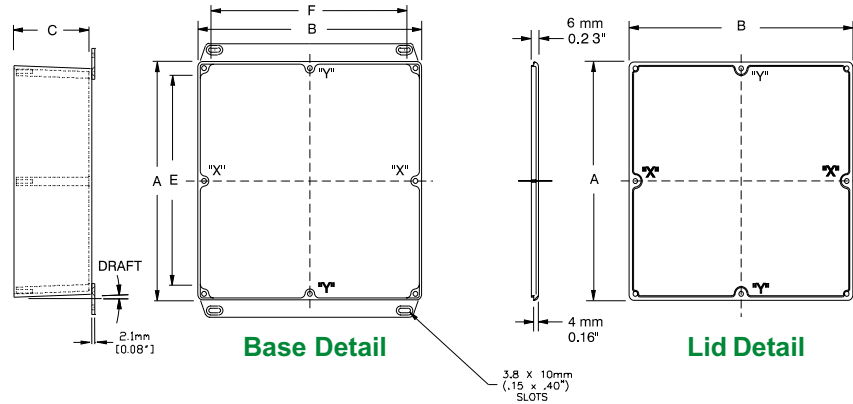

Part Number		Units	Dimensions					Apx. Draft
Unpainted	Black		A	B	C (No Lid)	E	F	
1590WLLBF	1590WLLBFBK	inch mm	1.97 50	1.97 50	0.83 21	1.22 31	1.22 31	1°15'
1590WLBFB	1590WLBFBK	inch mm	1.99 50.5	1.99 50.5	1.06 27	1.36 34.5	1.36 34.5	1°15'
1590WHFB	1590WHFBK	inch mm	2.07 52.5	1.50 38	1.06 27	1.41 35.9	.86 21.8	1°15'
1590WYFB	1590WYFBK	inch mm	3.62 92	3.62 92	1.50 38	2.70 69	2.70 69	1°15'
1590WAFB	1590WAFBK	inch mm	3.64 92.5	1.52 38.5	1.06 27	3.01 76.5	.89 22.5	1°15'
1590WGBF	1590WGBFK	inch mm	3.94 100	1.97 50	0.83 21	3.31 84	1.34 34	1°15'
1590WSFB	1590WSFBK	inch mm	4.35 110.5	3.21 81.5	1.57 40	3.72 94.5	2.58 65.5	1°15'
1590WBF	1590WBFBK	inch mm	4.39 111.5	2.34 59.5	1.06 27	3.76 95.5	1.71 43.5	1°15'
1590WBBFB	1590WBBFBK	inch mm	4.67 118.5	3.68 93.5	1.18 30	4.04 102.5	3.05 77.5	1°15'
1590WUFB	1590WUFBK	inch mm	4.70 119.5	4.70 119.5	2.17 55	4.07 103.5	4.07 103.5	1°15'
1590WVFB	1590WVFBK	inch mm	4.70 119.5	4.70 119.5	3.54 90	4.07 103.5	4.07 103.5	1°15'
1590WCFB	1590WCFBK	inch mm	4.72 120	3.70 94	2.07 52.5	4.09 104	3.07 78	2°
1590WQFB	1590WQFBK	inch mm	4.72 120	4.72 120	1.18 30	4.09 104	4.09 104	1°15'
1590WTFB	1590WTFBK	inch mm	4.74 120.5	3.13 79.5	2.17 55	4.11 104.5	2.50 63.5	1°15'
1590WN1FB	1590WN1FBK	inch mm	4.77 121.1	2.60 66	1.39 35.3	4.09 103.8	1.92 48.7	1°15'
1590WKKFB	1590WKKFBK	inch mm	4.92 125	4.92 125	2.10 53	4.13 105	4.13 105	1°15'
1590WKFB	1590WKFBK	inch mm	4.92 125	4.92 125	2.95 75	4.27 108.5	4.27 108.5	1°15'
1590WJFB	1590WJFBK	inch mm	5.71 145	3.74 95	1.77 45	5.06 128.5	3.09 78.5	2°
1590WP1FB	1590WP1FBK	inch mm	6.01 153	3.24 82	1.81 46	5.38 137	2.48 63	2°
1590WDDFB	1590WDDFBK	inch mm	7.38 187.5	4.70 119.5	1.30 33	6.77 172	4.07 103.5	1°15'
1590WDFB	1590WDFBK	inch mm	7.38 187.5	4.70 119.5	2.05 52	6.75 171.5	4.07 103.5	2°
1590WEFB	1590WEFBK	inch mm	7.38 187.5	4.70 119.5	3.07 78	6.75 171.5	4.07 103.5	2°
1590WFFB	1590WFFBK	inch mm	7.38 187.5	7.38 187.5	2.48 63	6.75 171.5	6.75 171.5	2°
1590WR1FB	1590WR1FBK	inch mm	7.55 192	4.38 111	2.24 57	6.92 176	3.76 95.4	2°

Notes: Assembled height = dimension "C" + .16" (4.0 mm). Wall & lid thickness is roughly .08" (2 mm) and varies with draft due to part being cast. Posts "X" exist on parts 1590D, 1590DD & 1590E. Posts "X" & "Y" exist on part 1590F. For detailed drawings, CAD files or color photos visit our website at: www.hammondmg.com

Sealed Diecast



CANADA
Guelph, Ontario (519) 822-2960
St. Laurent, Quebec (514) 343-9010
USA
Cheektowaga, NY (716) 651-0086

www.hammondmg.com

EUROPE
Basingstoke, UK +44 1256 812812

AUSTRALASIA
Queenstown, SA, Australia +61 8 8240 2244